

Flexo

Design

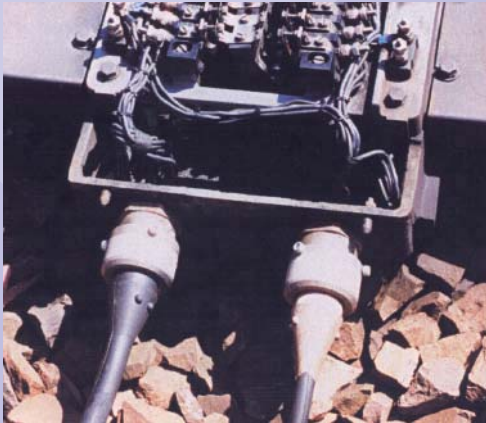
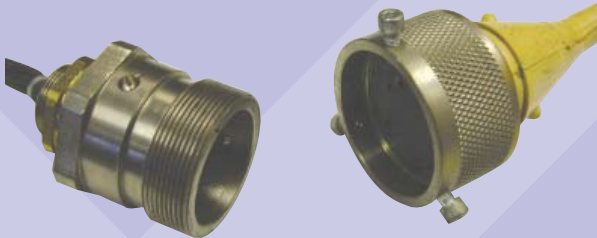

Quality Assurance

Configuration

- > Provides a reliable, easy to install connection from the point machine to the disconnect box. The cornerstone of the design is a plug and socket arrangement on the point machine. Preterminated leads complete the system with a socket on one end and a moulded palm on the other. Possession times are dramatically reduced by using the Prysmian plug coupler system.
 - Specially designed for use with Alstom HW point machine
 - Nickel plated brass plug and socket arrangement will not deteriorate during service
 - Vulcanised neoprene, fully bonded to the cable sheath, provides a waterproof seal with excellent strain relief
 - Pre-terminated socket leads, available with moulded palm on the other end of the cable
 - Available in standard lengths: 5m, 10m, 15m and 20m. Any required length can be supplied in 5m increments
 - Designed for use with Prysmian Disconnect Boxes (please see separate datasheet)
 - Low smoke, zero halogen cable version is available
 - Quick, accurate connection at disconnect box
 - Satisfies the continuous drive within the rail industry for improvements to trackside electrical connections
- > A 100% testing regime is rigorously employed. Every lead is electrically tested at the factory for voltage withstand, insulation resistance and correct continuity. The plug & socket can only be coupled one way.
- > Tactile locator pips ensure that correct orientation can easily be achieved in the worst conditions. It is impossible to terminate incorrectly.
- > **Plug coupler:** For fitting to the point machine. Available in 4 Way & 10 Way configurations.
- > **Socket coupler with free cable end:** For connecting the point machine to a disconnect box, hard wired. Available in 4 Way & 10 Way configurations.
- > **Socket coupler with moulded termination on cable end:** For connecting the point machine to a disconnect box, quick assembly. This solution offers the speediest installation. Available in 4 Way & 10 Way configurations.
- > **Moulded termination and free end:** For connecting the disconnect box to the location cabinet. Available in 4 Way & 10 Way configurations.
- > The Prysmian Point Machine Coupler System holds Network Rail approval PAS05/297.
- > Cables: C2 and E2 cables comply with RT/E/PS/00005.

Ref: PMCS/10/06

Approvals



UNIT 14 PARK COURT | SULLIVANS WAY | ST. HELENS | WA9 5GZ | UK

Tel: +44 (0)1744 762 929 | Fax: +44 (0)1744 762 930

Email: sales@etechcomponents.com | Web: www.e-tech-components.co.uk

Points Machine Coupler System

Selection Tables

Plug Coupler

Prysmian Catalogue Number	RI Catalogue Number	Description
W7 2280 01 01	88/000500	1m Tails - 4 Way
W7 2279 01 01	88/000501	1m Tails - 10 Way

4 Way Socket to Moulded Termination

Prysmian Catalogue Number	RI Catalogue Number	Length (m)
W7 2287 05 01	88/000520	5
W7 2287 10 02	88/000521	10
W7 2287 15 03	88/000522	15
W7 2287 20 04	88/000523	20

Disconnection Boxes for point machine plug coupler system

Prysmian Catalogue Number	RI Catalogue Number	Description
W7 9212 00 01	88/000502	4 Way plus 4 Way
W7 9213 00 01	88/000503	10 Way plus 10 Way

10 Way Socket to Moulded Termination

Prysmian Catalogue Number	RI Catalogue Number	Length (m)
W 2286 05 01	88/000524	5
W7 2286 10 02	88/000525	10
W7 2286 15 03	88/000526	15
W7 2286 20 04	88/000527	20

4 Way Socket to Free End

Prysmian Catalogue Number	RI Catalogue Number	Length (m)
W7 2270 05 01	88/000504	5
W7 2270 10 02	88/000505	10
W7 2270 15 03	88/000506	15
W7 2270 20 04	88/000507	20

4 Way Moulded Termination to Free End

Prysmian Catalogue Number	RI Catalogue Number	Length (m)
W7 2289 05 01	88/000512	5
W7 2289 10 02	88/000513	10
W7 2289 15 03	88/000514	15
W7 2289 20 04	88/000515	20

10 Way Socket to Free End

Prysmian Catalogue Number	RI Catalogue Number	Length (m)
W7 2269 05 01	88/000508	5
W7 2269 10 02	88/000509	10
W7 2269 15 03	88/000510	15
W7 2269 20 04	88/000511	20

10 Way Moulded Termination to Free End

Prysmian Catalogue Number	RI Catalogue Number	Length (m)
W7 2290 05 01	88/000516	5
W7 2290 10 02	88/000517	10
W7 2290 15 03	88/000518	15
W7 2290 20 04	88/000519	20

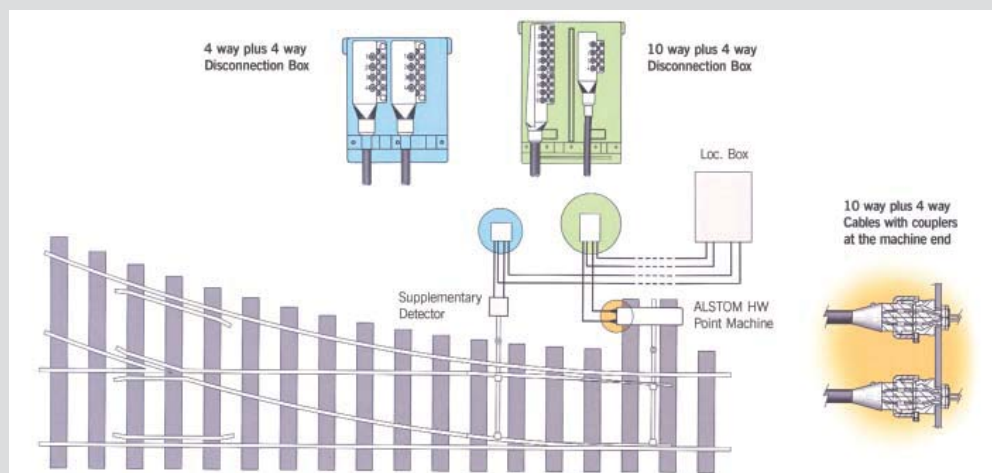

Reputation

- > With origins stretching back over 100 years, Prysmian have an enviable reputation for product quality and innovative design.
- > Components manufactures and supplies to accredited Business Management Systems BS EN 9001 and 14001 and is certified to OHSAS 18001.

