

METERING LINK DISCONNECT BOX AND MINI PILLAR



Low Voltage Underground Metering Link Disconnect Box

Type: 82212M30F



METERING LINK DISCONNECT BOX AND MINI PILLAR

Introduction

Prysmian Cables & Systems Limited offers a solution for Independent Distribution Network Operators (IDNOs) to connect to Distribution Network Operator (DNO) networks and monitor power consumption of their private network.

All units are tested in-house prior to shipping and have individual serial numbers.

Testing incorporates a minimum 500Vdc insulation resistance test and core assignment testing. Current transformer test certificates and wiring diagrams are provided.

The product is patented under (WO/2009/083026) DNO/IDNO LINK DISCONNECTING UNIT.

Each unit consists of:

An underground metering link disconnect box (MLDB) assembly which incorporates:

- > Link chambers
- > Neutral generating post
- > 3 x transparent chamber covers
- > 3 x "J" type fuse carriers
- > 1 x diving bell cover
- > 1 x watertight mini-pillar connection cable isolation box:
 - 1 x 13 way current test block
 - 3 x NNS type fuse carriers and 6 amp fuses
 - 1 x NNS type fuse carrier and neutral link
- > 3 x 400/5 current transformers
- > 2 x additional pit segments
- > 1 x concrete cover and steel frame with height adjuster
- > 1 x insulated lockable access bar
- > 3mts of 3 core x 300mm² waveform cable on load and supply side
- > 5mts of 12 core x 2.5mm² SWA cable for connection to mini pillar

A mini pillar assembly which is pre-wired and supplied with:

- > 1 x 13 way current test block
- > 3 x NNS type fuse carriers and 2 amp fuses
- > 1 x NNS type fuse carrier and neutral link
- > M25 gland plate for mini-pillar cable connection and securing
- > 1 x connection cable termination kit:
 - M25 cable gland
 - Pre-insulated crimps
 - Wiring diagrams for mini pillar and MLDB

The MLDB base assembly is fully tested in-house prior to shipping and comes with all the necessary components to connect both the base unit and mini pillar together.



UNIT 14 PARK COURT | SULLIVANS WAY | ST. HELENS | WA9 5GZ | UK

Tel: +44 (0)1744 762 929 | Fax: +44 (0)1744 762 930
Email: sales@etechcomponents.com | Web: www.e-tech-components.co.uk

 **PRYSMIAN**
CABLES & SYSTEMS

METERING LINK DISCONNECT BOX DESCRIPTION

Insulated extendable locking bar (lock not supplied)

Watertight mini-pillar connection cable isolation box housing current-test block and fuses

Watertight "mini-pillar connection cable" isolation box contents

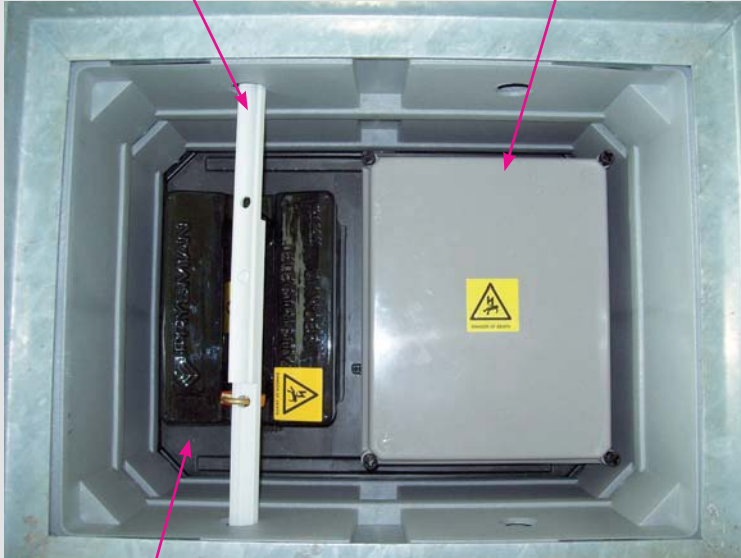

Diving bell cover housing link chambers, chamber covers, fuse carriers and neutral generator contact post

Typical wiring diagram

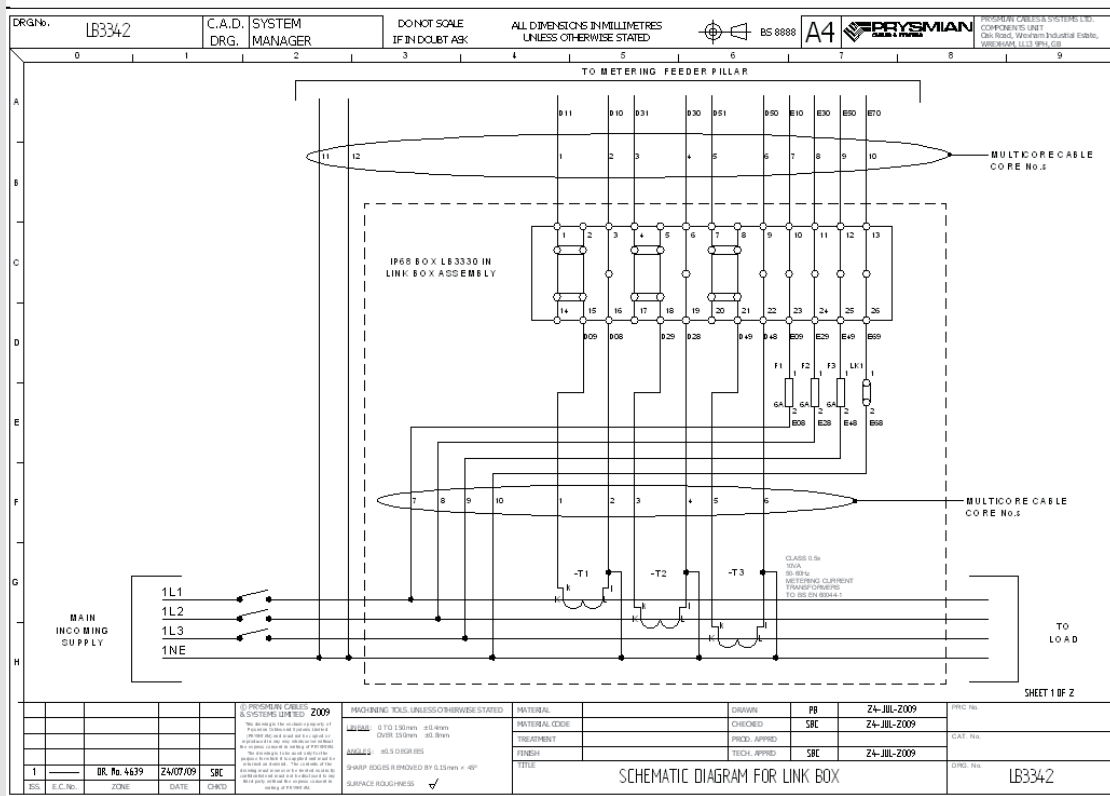

UNIT 14 PARK COURT | SULLIVANS WAY | ST. HELENS | WA9 5GZ | UK

Tel: +44 (0)1744 762 929 | Fax: +44 (0)1744 762 930

Email: sales@etechcomponents.com | Web: www.e-tech-components.co.uk

MINI PILLAR DESCRIPTION

- > The mini pillar comes with the current test block and fuse carriers pre-wired along with flying leads to connect to the operators required meter
- > The back board can accommodate both the operators meter and a secondary check meter if required
- > A document holder is also provided to hold any certificates along with the supplied wiring diagrams and current transformer test certificates

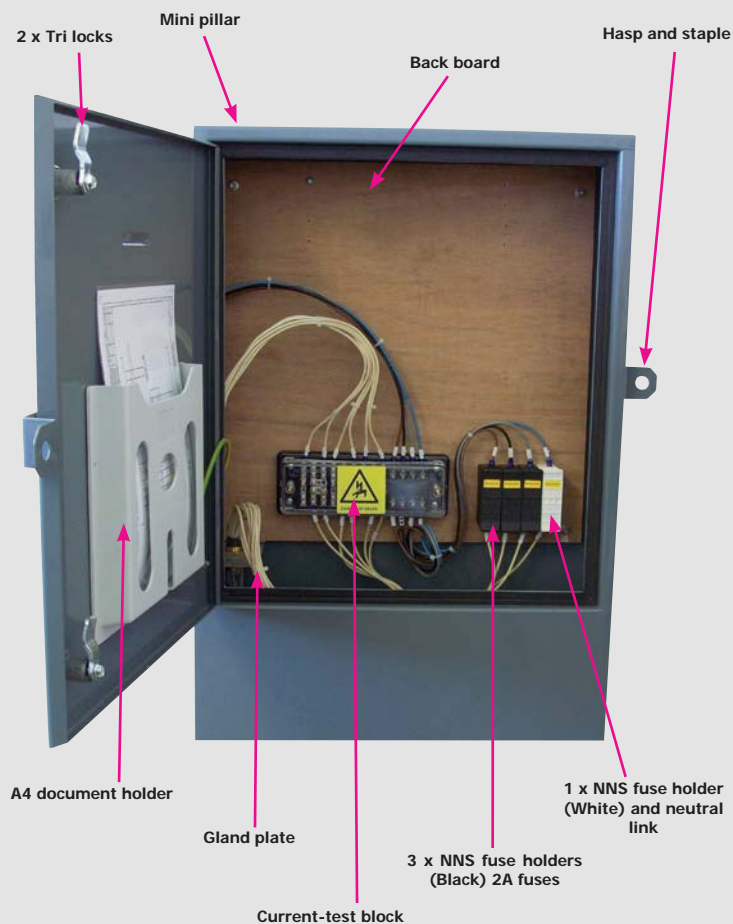

SPECIFICATION

As well as being tested in-house during assembly the MLDB has undergone various tests on both its assembly and component parts. Each unit is fully tested for both electrical connectivity and correct core assignment and is provided with a full set of wiring diagrams that cover both the mini pillar and the MLDB main assembly. The following tests have also been completed and test reports are available upon request.

- > Tested and approved to BS EN 50393 & ER C81/3 for 600/1000 volt cable accessories
Test reference PCL/T/698
- > Temperature Rise and Live Make and Break to BS EN 60947 Pt 1 and Pt 3
Test reference PCL/T/567
- > BS EN 124 class B125 gully tops and manhole tops for vehicular and pedestrian areas
- > BS 5467 Multi-core armoured cable, 12 core 2.5mm²
- > BS 7870-3.40 600/1000 volt Waveform Cable
- > BS EN 60044-1 Transformers, 400/5 ratio, class 0.5s, 10VA and 50-60 Hz
Test reports supplied for each transformer installed

- > BS 88-Part 1 –Part 5 and Part 6-(1988) fusing in both isolation box and mini pillar 550Vac, 80kA rated, 6amp within isolation box and 2amp in mini pillar
- > Isolation box allows for complete isolation of mini pillar from link box
- > Mini pillar rated at IP54.
Manufactured from 2mm thick BE-EN 10088-2 stainless steel, powder coated to BS 381C 632 at 70 micron thickness

Typically supplied with:

- > BS 88 NSS type fuses and neutral links
- > "J" type fuse carriers with 83mm centres
- > Locking mechanism to prevent unauthorised access during maintenance works
- > Wiring diagrams and mini-pillar connection cable termination kit
- > Certificate of conformance and current transformer test reports



UNIT 14 PARK COURT | SULLIVANS WAY | ST. HELENS | WA9 5GZ | UK

Tel: +44 (0)1744 762 929 | Fax: +44 (0)1744 762 930
Email: sales@etechcomponents.com | Web: www.e-tech-components.co.uk

DIMENSIONS

Installation:

- > Minimal on-site assembly.
- > Mini-pillar is pre-wired to accept mini-pillar connection and meter.
- > Height adjustable pavement frame and cover to ensure flush fitting with pavement level.
- > Pre-installed 300mm² waveform tails are supplied ready to connect onto LV network.
- > Units supplied marked "SUPPLY" and "LOAD" for indication.

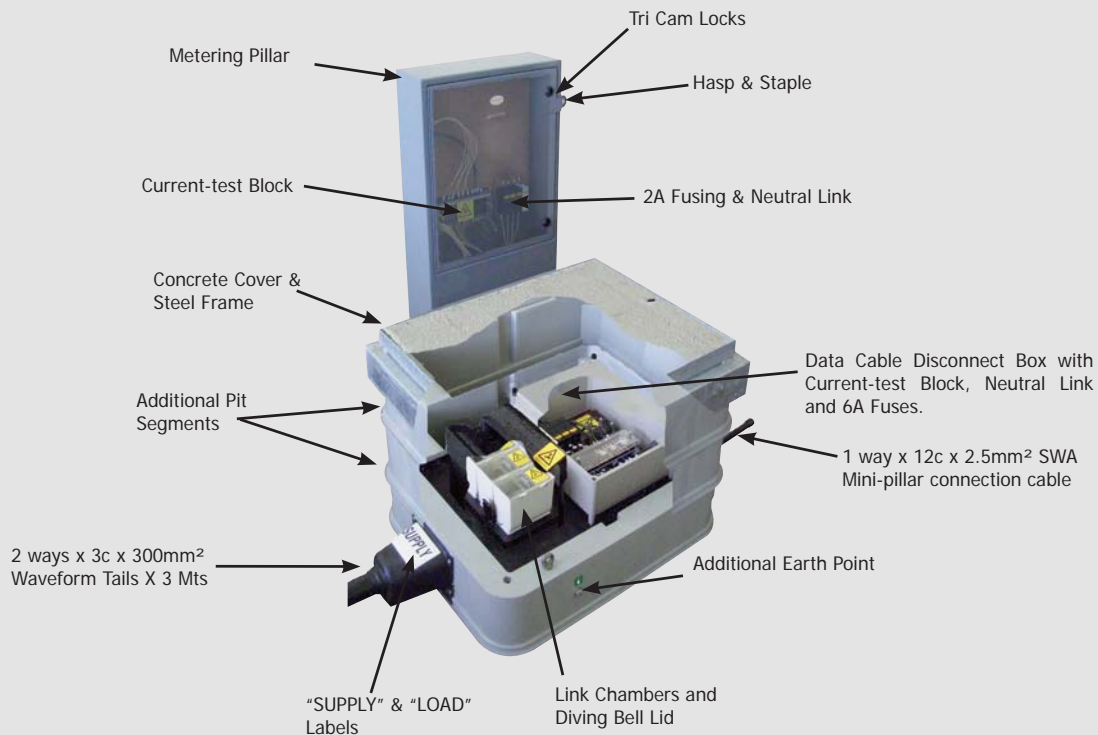

Dimensions:

- > Weight: 230Kg.
- > 2 x 3 metre lengths of 3c x 300mm² BS 7870-3.40 600/1000 volt waveform cable.
- > 1 x 5 metre length of 12c x 2.5mm² BS 5467 SWA mini-pillar connection cable.

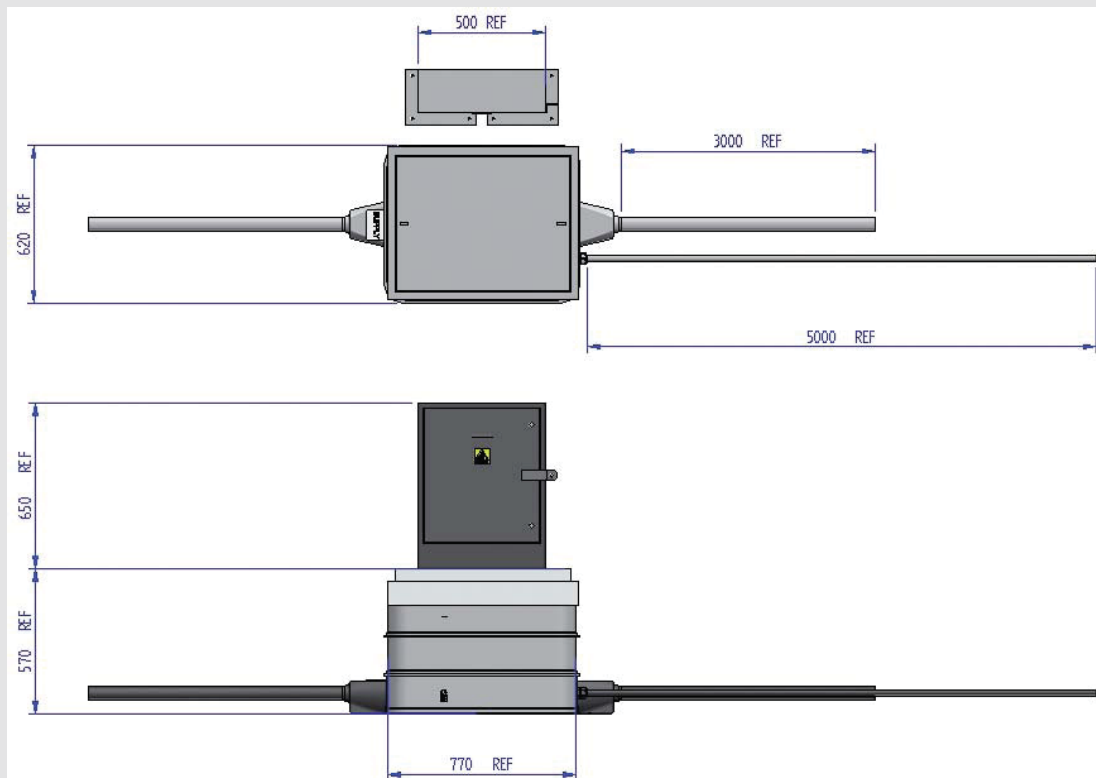

UNIT 14 PARK COURT | SULLIVANS WAY | ST.HELENS | WA9 5GZ | UK

Tel: +44 (0)1744 762 929 | Fax: +44 (0)1744 762 930
Email: sales@etechcomponents.com | Web: www.e-tech-components.co.uk